

## GLOBE VALVE: THREADED X FLANGED (B16.5)

Stainless Steel

### FEATURES

- ◆ 200WOG globe valve
- ◆ Working pressure: 200PSI\*
- ◆ Rising stem
- ◆ Disc: ASTM A351 CF8M
- ◆ Body: ASTM A351 CF8M
- ◆ Seat: 316SS
- ◆ Threaded bonnet
- ◆ Flange: 316SS Class 150 ANSI B16.5
- ◆ Square-head pipe plug: brass
- ◆ Adjustable stem packing
- ◆ Temperature range: -58°F to 350°F  
(-50°C to 176°C)
- ◆ Test standard: API 598
- ◆ Open/close position indicator

### OPTION

- ◆ Square-head pipe plug:  
available in 304SS/316SS
- ◆ Flange: available in 304SS
- ◆ Padlocking device
- ◆ Graduated open/close  
position indicator

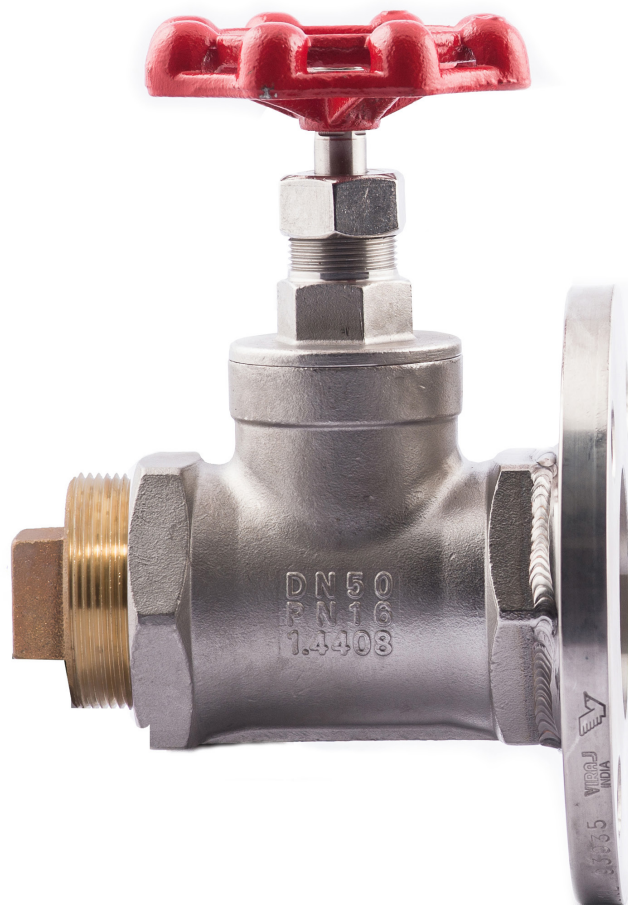

\* Flanged assemblies: the pressure capacity of valve and flange assembly is restricted to the flange and not the valve.

# GLOBE VALVE: THREADED X FLANGED (B16.5)

Stainless Steel

DIMENSIONS											
SIZE	L+/-5	D	K	D1	H	N	D2	P	W	T	a
½"	77	89	60.4	35	66	4	16	NPT ½"	70	11.2	45
¾"	81	98.5	70	42.9	99	4	16	NPT ¾"	70	12.7	45
1"	92.5	108	79	50.8	102	4	16	NPT 1"	76.5	14.2	45
1 ½"	115	127	99	73.1	136	4	16	NPT 1 ½"	103.5	17.2	45
2"	130	152.4	120.6	92	156	4	19	NPT 2"	121	19	45

\* All dimensions recorded in millimeters

MATERIALS LIST			
No	PART	MATERIAL	QTY
1	NUT	304SS	1
2	HANDWHEEL	400SS	1
3	STEM	ASTM A276 316SS	1
4	GLAND NUT	ASTM A351 CF8M	1
5	GLAND	ASTM A351 CF8M	1
6	GLAND PACKING	PTFE	1
7	BONNET	ASTM A351 CF8M	1
8	GASKET	PTFE	1
9	BODY	ASTM A351 CF8M	1
10	DISC	ASTM A351 CF8M	1
11	PIPE PLUG	BRASS	1
12	FLANGE	316SS	1

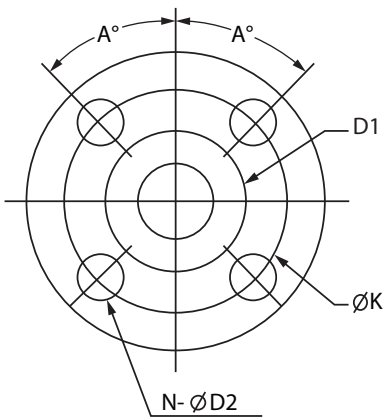
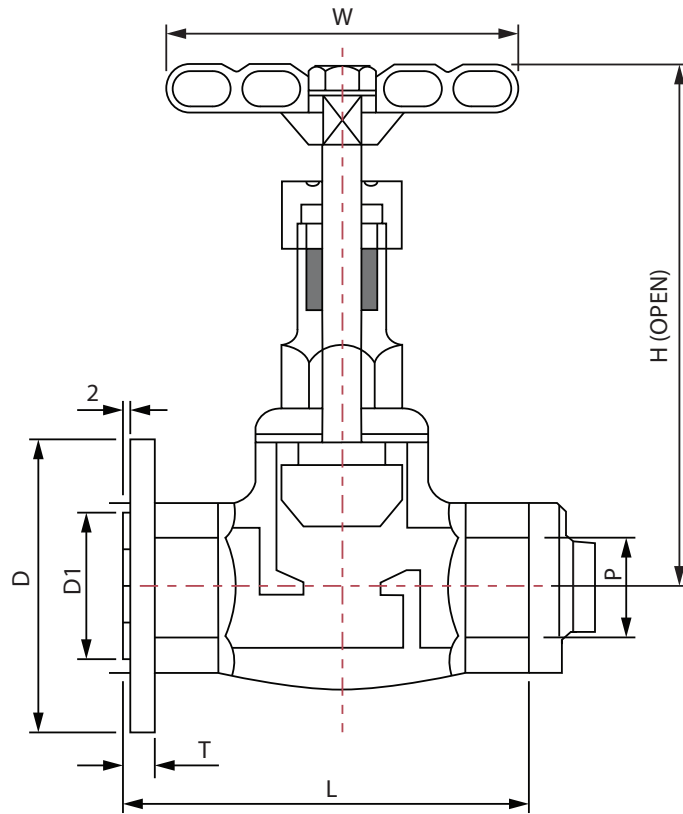

Holes applied evenly, symmetrically to the axis.

# THERMOFLEX

Thermoflex 2136 Rue Léger, LaSalle, Québec, H8N 2L8, Canada

1-888-352-3414 514-367-1444 514-367-3193

thermoflex@bellnet.ca thermoflex.ca