

GATE VALVE: THREADED X FLANGED (B16.5) Stainless Steel

FEATURES

- ◆ Full port 200WOG gate valve
- ◆ Working pressure: 200PSI*
- ◆ Non-rising stem
- ◆ Disc: ASTM A351 CF8M
- ◆ Body: ASTM A351 CF8M
- ◆ Threaded bonnet
- ◆ Flange: 316SS Class 150 ANSI B16.5
- ◆ Square-head pipe plug: brass
- ◆ Adjustable stem packing
- ◆ Temperature range: -58°F to 350°F
(-50°C to 176°C)
- ◆ Test standard: API 598
- ◆ Open/close position indicator

OPTION

- ◆ Square-head pipe plug:
available in 304SS/316SS
- ◆ Flange: available in 304SS
- ◆ Padlocking device
- ◆ Graduated open/close
position indicator

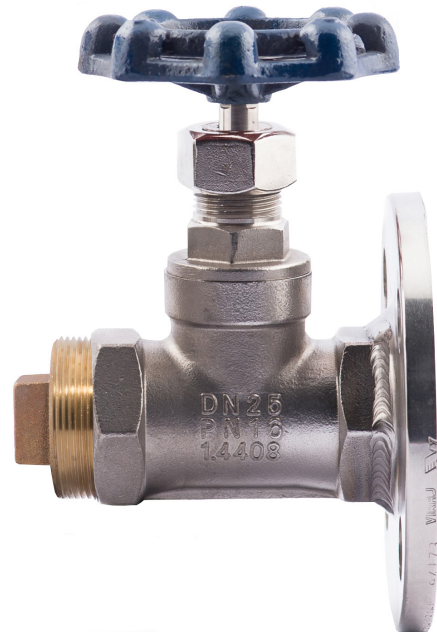

* Flanged assemblies: the pressure capacity of valve and flange assembly is restricted to the flange and not the valve.

GATE VALVE: THREADED X FLANGED (B16.5)

Stainless Steel

DIMENSIONS											
SIZE	L+/-5	D	K	D1	H	N	D2	P	W	T	a
½"	68	89	60.4	35	98	4	16	NPT ½"	70	11.2	45
¾"	73	98.5	70	42.9	103	4	16	NPT ¾"	70	12.7	45
1"	81	108	79	50.8	115	4	16	NPT 1"	76.5	14.2	45
1 ½"	104	127	99	73.1	173	4	16	NPT 1 ½"	103.5	17.2	45
2"	114	152.4	120.6	92	189	4	19	NPT 2"	121	19	45

* All dimensions recorded in millimeters

MATERIALS LIST		
PART	MATERIAL	QTY
BODY	ASTM A351 CF8M	1
BONNET	ASTM A351 CF8M	1
STEM	ASTM A276 316SS	1
DISC	ASTM A351 CF8M	1
GASKET	PTFE	1
STOP RING	304SS	1
STEM HOLDER	316SS	1
STEM PACKING	PTFE	1
GLAND	304SS	1
GLAND NUT	316SS	1
HAND WHEEL	400SS	1
INDICATOR PLATE	ALUMINUM	1
HAND WHEEL WASHER	304SS	1
HAND WHEEL NUT	304SS	1
PIPE PLUG	BRASS	1
FLANGE	316SS	1

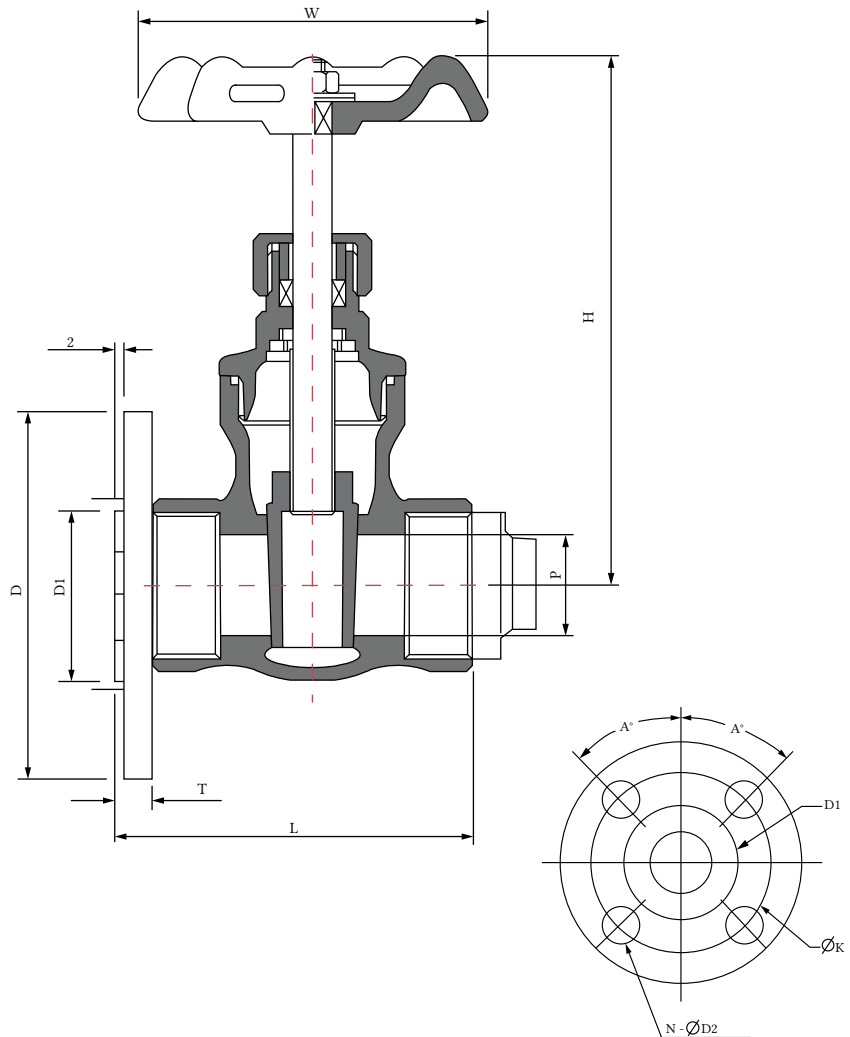

Holes applied evenly, symmetrically to the axis.

THERMOFLEX

Thermoflex 2136 Rue Léger, LaSalle, Québec, H8N 2L8, Canada

☎ 1-888-352-3414 514-367-1444 📠 514-367-3193

✉ thermoflex@bellnet.ca 🌐 thermoflex.ca