

BALL VALVE: 2-PIECE THREADED X FLANGED (B16.5)

Stainless Steel

FEATURES

- ◆ Full port 1000WOG* ball valve
- ◆ Steam rating: 150PSI* WSP
- ◆ Blow-out-proof stem
- ◆ Body: ASTM A351 CF8M
- ◆ Ball: ASTM A351 CF8M
- ◆ Stem: ASTM A276 316SS
- ◆ Flange: 316SS Class 150 ANSI B16.5
- ◆ Square-head pipe plug: brass
- ◆ Adjustable stem packing
- ◆ Seat: reinforced teflon (RTFE)
- ◆ Working pressure: 150PSI*
- ◆ Temperature range: -58°F to 450°F (-50°C to 232°C)
- ◆ Test standard: API 598
- ◆ Padlocking device
- ◆ Open/close position indicator

OPTION

- ◆ Square-head pipe plug: available in 304SS/316SS
- ◆ Flange: available in 304SS

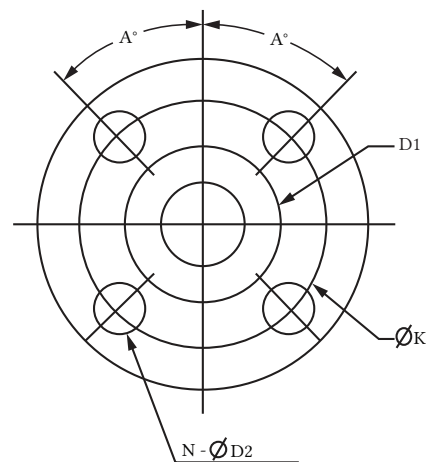

Holes applied evenly,
symmetrically to the axis.

* Flanged assemblies: the pressure capacity of valve and flange assembly is restricted to the flange and not the valve.

BALL VALVE: 2-PIECE THREADED X FLANGED (B16.5)

Stainless Steel

DIMENSIONS											
SIZE	L+/-5	D	K	D1	H+/-5	N	D2	P	E+/-5	T	a
½"	77.5	89	60.4	35	55	4	16	NPT ½"	100	11.2	45
¾"	86	98.5	70	42.9	65	4	16	NPT ¾"	100	12.7	45
1"	99	108	79	50.8	70	4	16	NPT 1"	125	14.2	45
1 ½"	135	127	99	73.1	90	4	16	NPT 1 ½"	150	17.2	45
2"	151	152.4	120.6	92	100	4	19	NPT 2"	195	19	45
3"	221	190.5	152.5	127	125	4	19	NPT 3"	280	23.9	45

* All dimensions recorded in millimeters

MATERIALS LIST		
PART	MATERIAL	QTY
BODY	ASTM A351 CF8M	1
CAP	ASTM A351 CF8M	1
BALL	ASTM A351 CF8M	1
STEM	ASTM A276 316SS	1
SEAT	RTFE (+15% GF)	2
GASKET	PTFE	1
THRUST WASHER	PTFE	1
PACKING	PTFE	1
GLAND	304SS	1
HANDLE	304SS	1
SPRING WASHER	304SS	1
HANDLE NUT	304SS	1
HANDLE SLEEVE	PLASTIC	1
LOCKING DEVICE	304SS	1
PIPE PLUG	BRASS	1
FLANGE	316SS	1

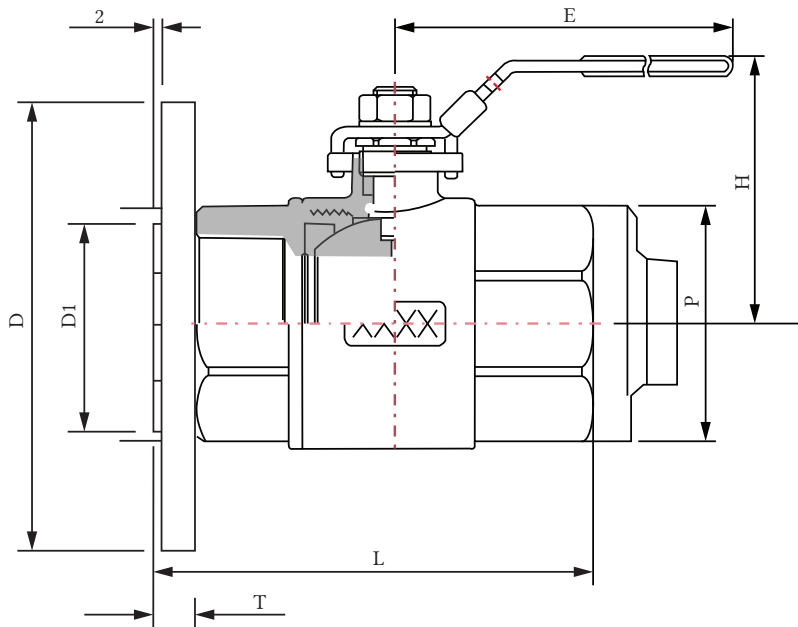

THERMOFLEX

Thermoflex 2136 Rue Léger, LaSalle, Québec, H8N 2L8, Canada

1-888-352-3414 514-367-1444 514-367-3193

thermoflex@bellnet.ca thermoflex.ca