

BALL VALVE: 3-PIECE THREADED X FLANGED (B16.24) SAMPLER

Stainless Steel

FEATURES

- ◆ Full port 1000WOG* ball valve
- ◆ Steam rating: 150PSI* WSP
- ◆ Blow-out-proof stem
- ◆ ISO 5211 actuator mounting pad
- ◆ Body: ASTM A351 CF8M
- ◆ Ball: ASTM A351 CF8M
- ◆ Stem: ASTM A276 316SS
- ◆ Flange: 316SS Class 150 ANSI B16.24
- ◆ Square-head pipe plug: brass
- ◆ Sampler: 3/8" 304SS
- ◆ Adjustable stem packing
- ◆ Seat: reinforced teflon (RTFE)
- ◆ Working pressure: 150PSI*
- ◆ Temperature range: -58°F to 450°F (-50°C to 232°C)
- ◆ Test standard: API 598
- ◆ Padlocking device
- ◆ Open/close position indicator

OPTION

- ◆ Socket weld X flanged
- ◆ Butt weld X flanged
- ◆ Square-head pipe plug: available in 304SS/316SS
- ◆ Flange: available in 304SS

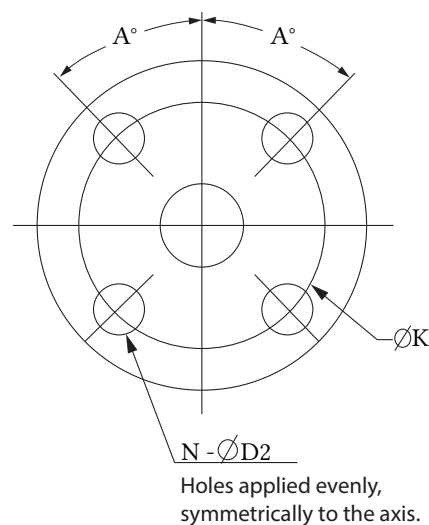
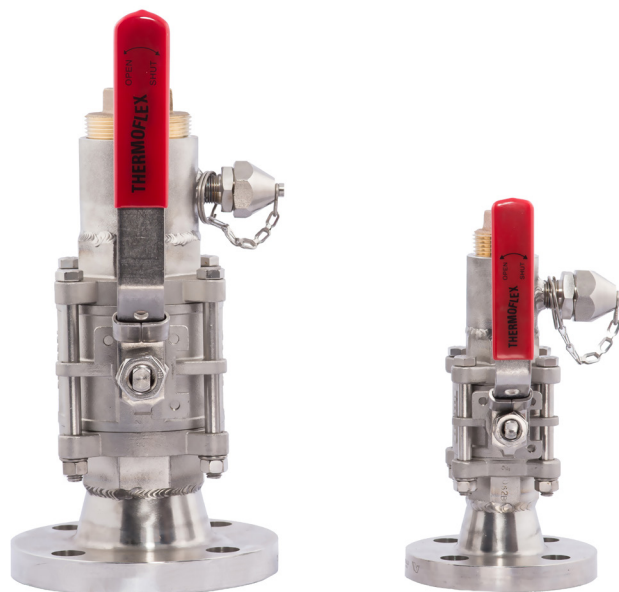

* Flanged assemblies: the pressure capacity of valve and flange assembly is restricted to the flange and not the valve.

BALL VALVE: 3-PIECE THREADED X FLANGED (B16.24) SAMPLER

Stainless Steel

DIMENSIONS										
SIZE	L+/-5	D	K	H+/-5	N	D2	P	E+/-5	T MIN	a
1"	179	108	79	70	4	16	NPT 1"	125	9.5	45
1 1/2"	212.5	127	99	95	4	16	NPT 1 1/2"	150	11	45
2"	243	152.4	120.6	100	4	19	NPT 2"	195	12.75	45
3"	311.5	190.5	152.5	135	4	19	NPT 3"	275	16	45

* All dimensions recorded in millimeters

MATERIALS LIST		
PART	MATERIAL	QTY
BODY	ASTM A351 CF8M	1
CAP	ASTM A351 CF8M	2
BALL	ASTM A351 CF8M	1
STEM	ASTM A276 316SS	1
SEAT	RTFE (+15% GF)	2
PACKING	PTFE	1
GLAND	304SS	1
END SEALS	PTFE	2
THRUST WASHER	PTFE	1
HANDLE	304SS	1
HANDLE NUT	304SS	1
SPRING WASHER	304SS	1
BOLTS	ASTM A193 B8	4-6
BOLT NUTS	ASTM A194 8	4-6
BOLT WASHERS	304SS	4-6
HANDLE SLEEVE	PLASTIC	1
LOCKING DEVICE	304SS	1
PIPE PLUG	BRASS	1
FLANGE	316SS	1
SAMPLER	304SS	1
EXTENSION	316SS	1

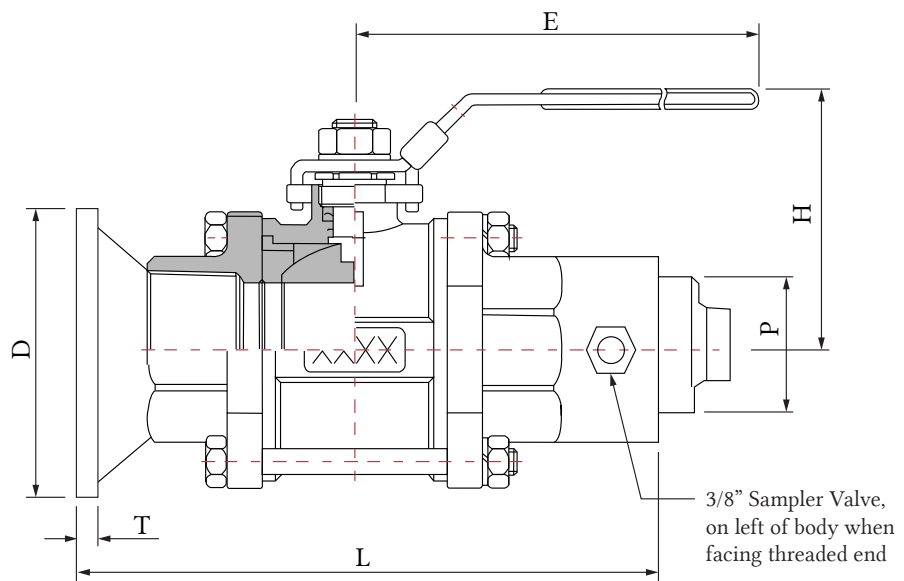

THERMOFLEX

Thermoflex 2136 Rue Léger, LaSalle, Québec, H8N 2L8, Canada

1-888-352-3414 514-367-1444 514-367-3193

thermoflex@bellnet.ca thermoflex.ca

A-10

DISCLAIMER: While every effort has been made to ensure the accuracy of the data herein, the data cited are subject to change without notice or liability.