

## BALL VALVE: 2-PIECE THREADED X FLANGED (B16.24)

Brass

### FEATURES

- ◆ Standard port 400WOG\* ball valve
- ◆ Self-cleaning and self-adjusting compressed seal
- ◆ Double O-ring stem
- ◆ Body: forged brass precision machined
- ◆ Ball: brass precision machined
- ◆ Stem: brass/chrome plated precision machined
- ◆ Flange: brass/cast bronze Class 150 ANSI 16.24
- ◆ Square-head pipe plug: brass
- ◆ O-rings: Buna-N (NBR)
- ◆ Seat: Buna-N (NBR)
- ◆ Prolonged life expectancy
- ◆ Working pressure 150PSI\*
- ◆ Temperature range: -50°F to 250°F (-45.5°C to 121°C)
- ◆ Open/close position indicator

### OPTION

- ◆ Padlocking device
- ◆ Sampling device

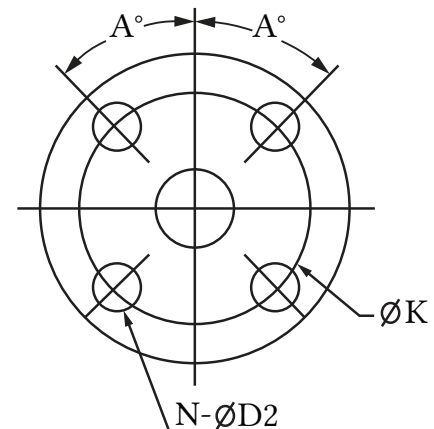
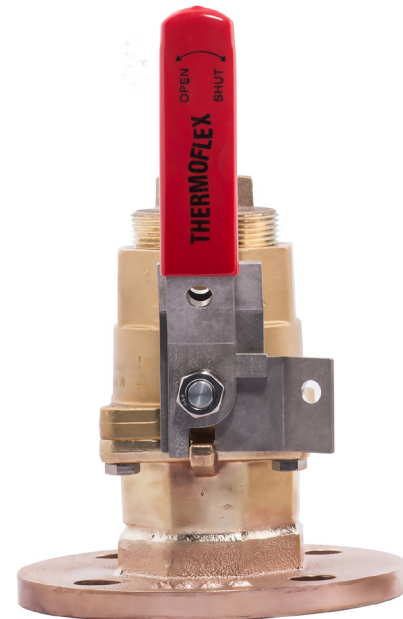

Holes applied evenly,  
symmetrically to the axis.

\* Flanged assemblies: the pressure capacity of valve and flange assembly is restricted to the flange and not the valve.

# BALL VALVE: 2-PIECE THREADED X FLANGED (B16.24)

Brass

DIMENSIONS										
SIZE	L+/-5	D(d)	K	H+/-5	N	D2	P	E+/-5	T min	a
1/2"	95	89	60.4	40	4	16	NPT 1/2"	95	8	45
3/4"	95	99	70	45	4	16	NPT 3/4"	110	8.75	45
1"	110	108	79	50	4	16	NPT 1"	110	9.5	45
1 1/2"	130	127	99	65	4	16	NPT 1 1/2"	145	11	45
2"	145	152	120.6	70	4	19	NPT 2"	145	12.75	45

(d) -0/+10 "D"

\* All dimensions recorded in millimeters

MATERIALS LIST			
No	PART	MATERIAL	QTY
1	BODY	FORGED BRASS	2
2	BALL	BRASS PRECISION MACHINED	1
3	SEATS	Buna-N (NBR)	2
4	SEAT O-RING	Buna-N (NBR)	1
5	JOINT O-RING	Buna-N (NBR)	1
6	STEM O-RING	Buna-N (NBR)	2
7	DISC	BRASS PRECISION MACHINED	1
8	SPRING	304SS	1
9	CAP SCREW	304SS	4
10	JAM NUT	304SS	1
11	STEM	BRASS/CHROME PLATED PRECISION MACHINED	1
	HANDLE	GALVANIZED/304SS	1
	HANDLE SLEEVE	PLASTIC	1
	LOCKING DEVICE OPTION*	304SS	1
	SAMPLING DEVICE OPTION*	BRASS PRECISION MACHINED	1

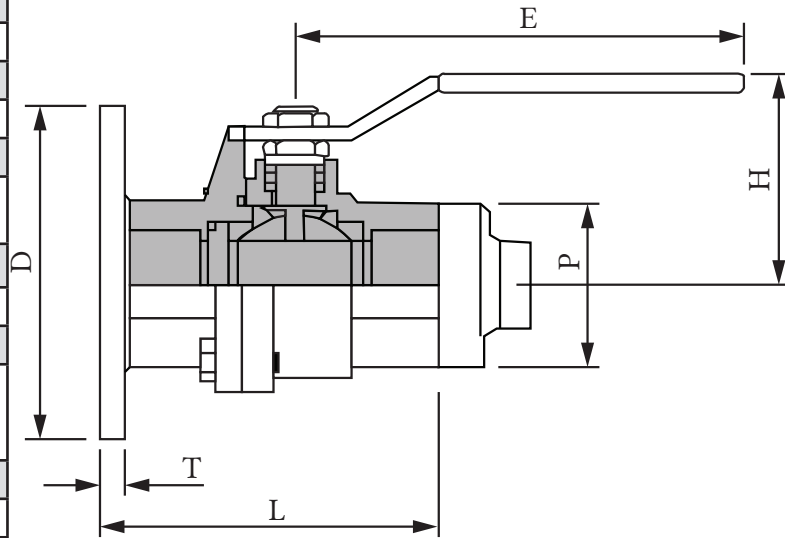

# THERMOFLEX

Thermoflex 2136 Rue Léger, LaSalle, Québec, H8N 2L8, Canada

1-888-352-3414 514-367-1444 514-367-3193

thermoflex@bellnet.ca thermoflex.ca